



AIRCHARGER®

HIGH-FLOW INTAKE KITS

NOT LEGAL FOR SALE OR USE ON ANY POLLUTION CONTROLLED MOTOR VEHICLE IN CALIFORNIA OR STATES ADOPTING CALIFORNIA EMISSION PROCEDURES.
See knfilters.com for CARB status on each part for a specific vehicle

INSTALLATION INSTRUCTIONS

63-1141

CAN-AM

2017-20 Maverick X3 Turbo R

899CC Turbo

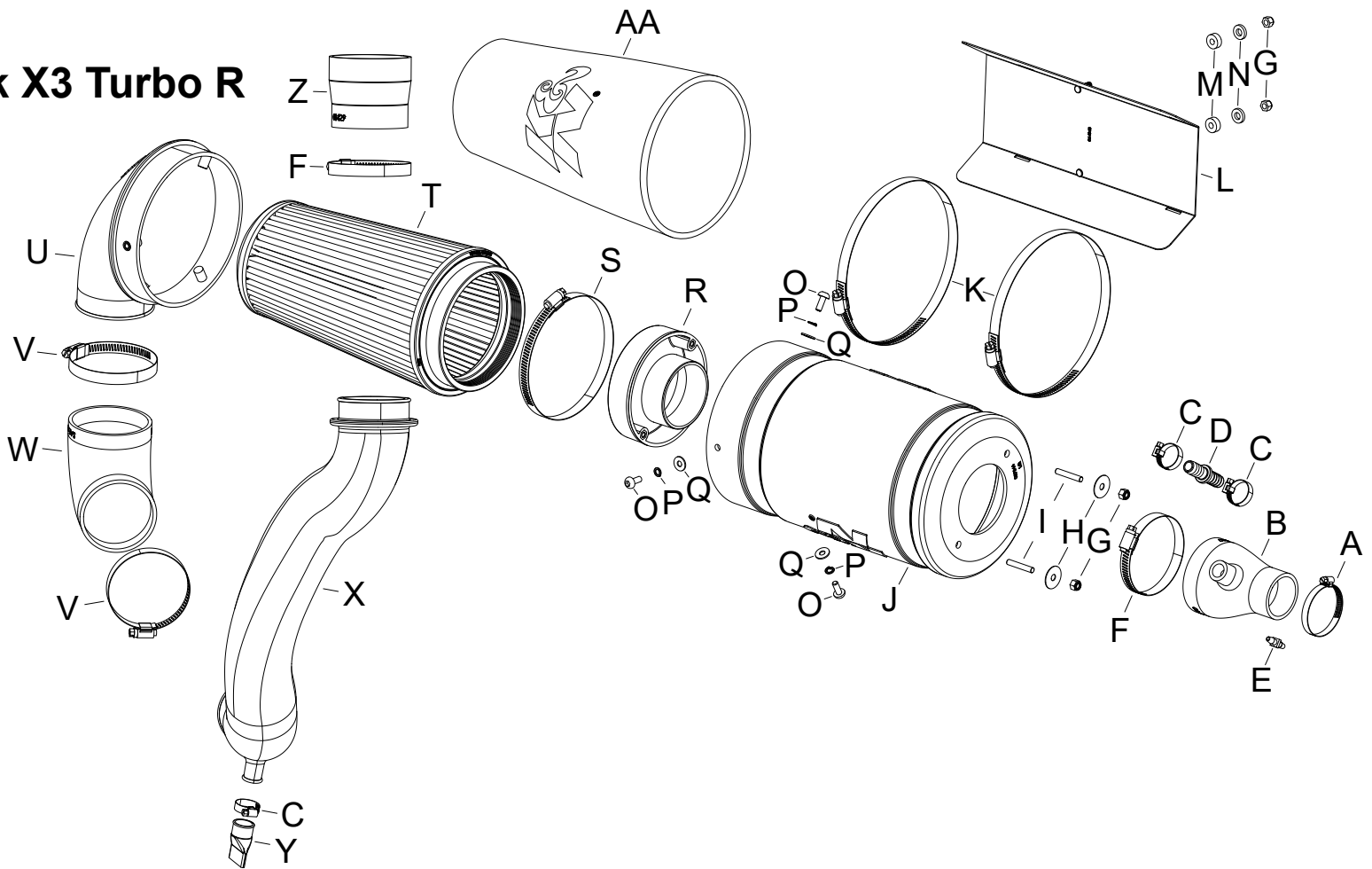

TOOLS NEEDED:

- flat blade screw driver
- ratchet
- extension
- 13mm socket
- 10mm socket
- 8mm socket
- 7mm socket
- t30 torx
- t15 torx
- pliers
- 10mm wrench

PARTS LIST:

Description	Qty.	Part #	Description	Qty.	Part #	Description	Qty.	Part #
A HOSE CLAMP; #28	1	08483	J CANNISTER; 63-1140, LQ,HDPE	1	087344A	S HOSE CLAMP; #80	1	08694
B HOSE; 1-3/4"ID TO 3"ID X 4-5/8"	1	084103	K HOSE CLAMP; #116	2	08647	T FILTER CHARGER	1	RU-5065XD
C HOSE CLAMP; #10 MINI	3	08411	L BRACKET; 63-1141, MILD STL	1	064348	U LID; 63-1141, LY, XLHDPE	1	087351A
D HOSE MENDER; 1/2" BARBED	1	08048	M SPACER; .625" OD X .250"ID	2	06555	V HOSE CLAMP; #52	2	08610
E HOSE MENDER; 3/16" X 3/16"	1	08703	N WASHER; 1/4"ID X 5/8"OD	2	08275	W HOSE; 3"ID TO 3-1/4"ID, 90	1	084102
F HOSE CLAMP; #48	2	08601	O BOLT; M6 X 1.00 X 16MM, SS	3	07734	X TUBE; FIPK 63-1141, LX, HDPE	1	087350A
G NUT; 6MM NYLOCK, HEXHEAD	4	07512	P WASHER; M6 SPLIT LOCK ZINC	3	07724	Y HOSE; DUCK BILL	1	08666
H WASHER; 1"D X 1/4 HOLE	2	08160	Q WASHER; 6MM FLAT, SS	3	08212	Z HOSE; 3-1/4" TO 3" ID X 3" L	1	08429
I STUD; 6MM-1.00 X 35MM L, SS	2	1-107	R ADAPTER; FILTER, 3.0"OD	1	21569	AA PRE-WRAP; RU-5065XD FOAM	1	973805

If you need any assistance please call 1-800-858-3333 to speak with a representative in our Customer Service Center before returning the product.

NOTE: FAILURE TO FOLLOW INSTALLATION INSTRUCTIONS AND NOT USING THE PROVIDED HARDWARE MAY DAMAGE THE INTAKE TUBE, THROTTLE BODY AND ENGINE.

TO START:

1. Turn off the ignition and disconnect the negative battery cable.
NOTE: Disconnecting the negative battery cable erases pre-programmed electronic memories. Write down all memory settings before disconnecting the negative battery cable. Some radios will require an anti-theft code to be entered after the battery is reconnected. The anti-theft code is typically supplied with your owner's manual. In the event your vehicles anti-theft code cannot be recovered, contact an authorized dealership to obtain your vehicles anti-theft code.



2. Remove the two fasteners securing the corner cap and then remove the corner cap from the vehicle.
NOTE: The cap is also held onto the chassis with a hidden clip on the back side.



3. Remove the five fasteners and clip nuts securing the top of the fender.



4. Remove the fastener on the bottom side near the tail light.



5. Remove the fastener securing the back side of the fender to the lower fender.



6. Open the door and remove the two fasteners securing the front of the fender.



7. Remove the fender partially and then unhook the tail lamp harness from the fender and then completely remove the fender from the vehicle.



8. Lift and remove the air intake cover.



9. Lift and remove the clutch filter.



10. Remove the turbo access panel from the firewall between the seats.



11. Loosen the hose clamp that secures the crank case vent hose to the intake hose and then disconnect the crank case vent hose. Cut the clamp that secures the vacuum hose to the air filter housing and then disconnect the vacuum hose. Loosen the hose clamp that secures the intake hose to the turbo inlet.



12. Loosen the hose clamp securing the intake flex hose to the air box.



13. Remove the intake flex hose from the plenum.



14. Loosen the hose clamp securing the clutch intake hose and disconnect the hose and set aside for access to the air filter assembly.



15. Remove the two bolts located behind the seat that secure the air filter housing to the firewall.



16. Remove the air filter housing assembly from the vehicle.
NOTE: K&N Engineering, Inc., recommends that customers do not discard factory air intake.



17. Install the two large hose clamps into the air filter housing mounting bracket as shown.
NOTE: the mounting bolts are off set to the left and the clamp adjusters are on the top in the photo.



18. Install the air filter mount into the vehicle so that the hose clamp adjusters are on the top and the bolts are off set to the left. Secure the mount with the hardware provided.

NOTE: Be sure to place the two provided spacers onto the studs before installing the air filter mount onto the firewall.



19. Install the two provided vent fittings into the K&N intake hose (084103) and secure the large fitting with the provided hose clamp.



20. Install the K&N intake hose assembly (084103) onto the turbo, rotate the hose so that the crank case vent hose aligns with the fitting installed into the K&N hose. Install the crank case vent hose and secure with the factory hose clamp. Connect the vacuum hose to the fitting installed into the K&N intake hose.

NOTE: Do not completely tighten the hose clamp securing the hose to the turbo at this time to allow adjustment to the air filter adapter.



21. Install the filter adapter into the K&N air filter and secure with the provided hose clamp.



21a. Install the pre-wrap onto the K&N air filter.



22. Install the K&N® air filter into the K&N® air filter housing and secure with the provided hardware.



23. Install the Air filter housing cover and secure with the provided hardware.



24. Install the air filter housing assembly onto the bracket and into the coupling hose at the turbo. Secure the housing with the hose clamps attached to the mounting bracket. Do not completely tighten at this time.



25. Install the duck bill onto the fresh air intake tube and secure with the provided hose clamp.



26. Feed the fresh air intake tube up into its location.



27. Install the 90° fresh air hose (084102) onto the air filter housing inlet and then onto the fresh air intake tube. Then secure with the provide hose clamps.



28. Install the fresh air intake hose (08429) onto the Fresh air intake tube. Adjust the tube so that it is tight against the housing, slide the hose down tight against the housing and then secure the hose clamp.



29. Adjust the air filter housing, turbo inlet hose and fresh air intake tube for best fit and then secure the hose clamps holding the air filter housing.



30. Reinstall the clutch fresh air intake hose and secure with the factory hose clamp.



31. Be sure the turbo inlet hose is fully seated onto the filter adapter and then secure the hose with the provided hose clamp. Reinstall the access panel.



32. Reinstall the clutch filter assembly.



33. Reinstall the intake cover.



34. Reinstall the fender and corner cover and secure with the factory hardware and clips.

35. Reconnect the vehicle's negative battery cable. Double check to make sure everything is tight and properly positioned before starting the vehicle.

36. It will be necessary for all K&N® high flow intake systems to be checked periodically for realignment, clearance and tightening of all connections. Failure to follow the above instructions or proper maintenance may void warranty.

ROAD TESTING:

1. Start the engine with the transmission in neutral or park, and the parking brake engaged. Listen for air leaks or odd noises. For air leaks secure hoses and connections. For odd noises, find cause and repair before proceeding. This kit will function identically to the factory system except for being louder and much more responsive.

2. Test drive the vehicle. Listen for odd noises or rattles and fix as necessary.

3. If road test is fine, you can now enjoy the added power and performance from your kit.

4. K&N Engineering, Inc., requires cleaning the intake system's air filter element every 100,000 miles. When used in dusty or off-road environments, our filters will require cleaning more often. We recommend that you visually inspect your filter once every 25,000 miles to determine if the screen is still visible. When the screen is no longer visible some place on the filter element, it is time to clean it. To clean and re-oil, purchase our filter Recharger® service kit, part number 99-5050 or 99-5000 and follow the easy instructions.

NOT LEGAL FOR SALE OR USE ON ANY POLLUTION CONTROLLED MOTOR VEHICLE IN CALIFORNIA OR STATES ADOPTING CALIFORNIA EMISSION PROCEDURES.

See knfilters.com for CARB status on each part for a specific vehicle