



R I N G B R O T H E R S

E4829 Hwy 14 • Spring Green, WI 53588 • 608.588.7399 • www.ringbrothers.com • marissa@ringbrothers.com

1071-1072

Billet Hood Hinge Kit Installation Instructions

Thank you for purchasing your set of billet hinges from Ringbrothers - the innovators of the billet hinges.

If you plan to disassemble the hinges before installation for polishing or plating you should know that all the bolts are assembled with blue Loctite. This should be done again when hinges are reassembled.

Packing List:

- 1 – Right hinge assembly
- 1 – Left hinge assembly
- 4 – 5/16" 3/4" button head bolts with washers for attaching hinge body to inner fender
- 4 – 5/16" x 1-1/4" button head bolts with washers for attaching hinge bracket to hood
- 2 – Gas Springs

CAUTION: Make sure ALL bolts are not too long for your application.

Tools Needed:

- Allen wrench for installing 5/16" button head bolts

Installation Steps:

1. Remove hood
 2. Remove factory hinges and try to hand tighten a button head bolt where each hinge bolt was removed. If the threads are damaged or corroded re-tap them with a 5/16" x 18 tap.
 3. Each hinge has a gas spring to hold the hood open.
NOTE: When installing the gas strut the barrel of the spring should always be above the rod to keep the lubrication on the rod and not ruin the spring. The spring should be installed after the hinge is mounted to the fender but before the hood is installed
 4. Position each hinge on the correct side and attach the hinge body to the inner fender with the 5/16" x 3/4" button head bolts. Before tightening the bolts completely move the hinge body up or down so the bolt is centered in the slot.
 5. Before you attach the hood you need to make sure that the hinges will close square. Measure the hood to hinge mounting holes. Measuring across the hood, record the length between the front two mounting holes. Then record the measurement between the rear two mounting holes on the hood. With the hinges mounted to the car you will need to measure and record the length between the front two holes on the hood bracket. Do the same for the rear two holes on the hood bracket – just as you did on the hood. You are making sure that the measurements are close because the hinges will NOT FLEX.
NOTE: it may be necessary to loosen the inner fender bolts to adjust the hinge mounting surface in or out.
NOTE: HINGES MUST CLOSE SQUARE! THEY WILL NOT FLEX!
-

6. Attach the hood to the hinges with the 5/16" x 1-1/4" button head bolts. Slide the hood forward as far as possible tightening the bolts. This will assure that the hood will not hit the cowl as it is lowered. Lower the hood **carefully**, watching the clearance front and back as well as both sides. Adjust the hood on the hinge brackets as needed for the correct clearance.
7. If adjustment is needed – adjust the fender brackets up or down for hood height first. Then adjust the hood back and forth on the hood bracket.

Any questions please call 608-588-7399
 Enjoy your new Ringbrothers Billet Hinges!

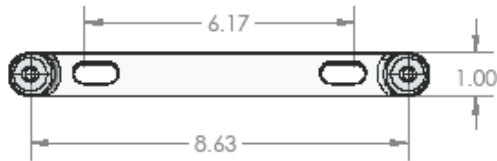
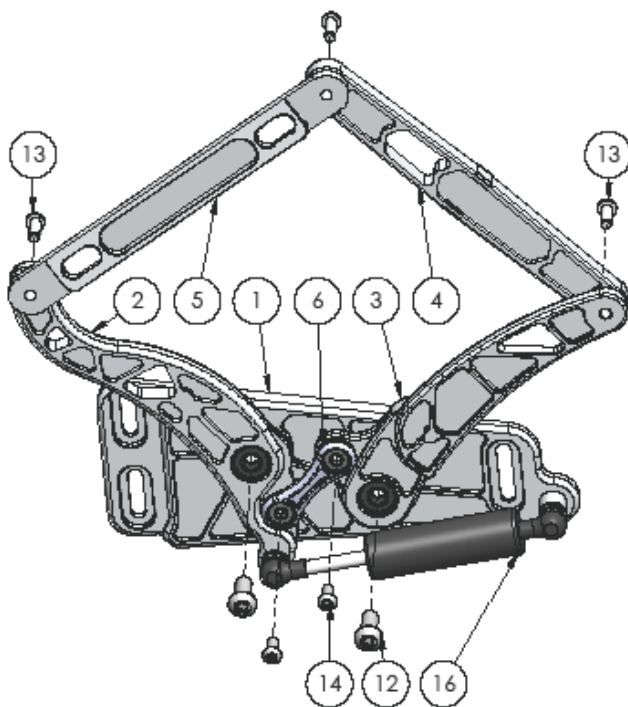

ITEM NO.	PART NUMBER	DESCRIPTION	QTY.
1	1072-001-D	FENDER BRACKET	1
2	1072-002-D	REAR ARM	1
3	1072-003-D	FRONT CONTROL ARM	1
4	1072-004-U	FRONT PUSH ARM	1
5	1072-005-U	HOOD BRACKET	1
6	1032-005-U	DOG BONE	1
ASSEMBLY HARDWARE			
7	D474489-FA	R4 BEARING	5
8	D474493-FA	R8 BEARING	2
9	5906K533-MC	3/8 ID X 3/4 OD	3
10	5906K549-MC	3/4 ID X 1 9/16 OD	2
11	91090A110-MC	.328 ID X .625 OD ZN	2
12	91306A419-MC	3/8-16 X 1 BHCS ZN	2
13	91306A379-MC	1/4-20 X 3/4 BHCS ZN	3
14	91306A377-MC	1/4-20 X 5/8 BHCS ZN	2
15	BALL STUD	10mm	2
HARDWARE KIT			
16	GAS STRUT	N/A	2
17	94744A245-MC	.344 ID X .625 OD	6
18	94744A249-MC	.344 ID X .875 OD	4
19	91306A391-MC	5/16-18 X 1 BHCS ZN	4
20	91306A404-MC	5/16-18 X 1 1/4 BHCS ZN	6

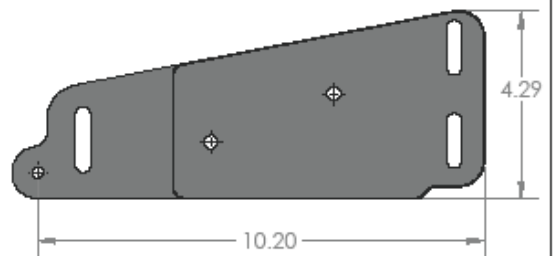

NOTES:

R		RINGBROTHERS	
<small> ALL DIMENSIONS ARE IN INCHES UNLESS OTHERWISE SPECIFIED. DIMENSIONS ARE TO CENTER UNLESS OTHERWISE SPECIFIED. DIMENSIONS ARE TO CENTER UNLESS OTHERWISE SPECIFIED. DIMENSIONS ARE TO CENTER UNLESS OTHERWISE SPECIFIED. DIMENSIONS ARE TO CENTER UNLESS OTHERWISE SPECIFIED. </small>		1072-000-D	
<small> NAME: DANIEL GERRIE ADDR: 847 GREEP PHONE: 531-232-1111 ADDR: ADDRESS NAME: STAN SCHWARTZ ADDR: ADDRESS PHONE: 531-232-1111 ADDR: ADDRESS </small>		A	B-BODY HOOD
<small> WWW.RINGBROTHERS.COM 1072-000-D </small>		<small>SCALE: 1/16" = 1"</small>	<small>DATE: 1/11/11</small>
<small>ADDRESS: CHICAGO</small>		<small>WWW.RINGBROTHERS.COM</small>	