



Installation Guide for 2015-17 Ford F150 | 2017-20 F150 Raptor Headlights

ALPHAREX specializes in designing and producing superior and uniquely stylish aftermarket automotive performance lighting with unrivalled innovative technology. This installation guide takes you through the step-by-step process of installing your new **ALPHAREX HEADLIGHTS** for your 2015-17 Ford F150 | 2017-20 F150 Raptor

DO NOT USE DIELECTRIC GREASE!



Table of Contents



PART I REMOVE HEADLIGHTS

- **INSTALLATION TOOLS**
- **STEP 1.** Disconnecting the negative battery terminal
- **STEP 2.** Remove the outer trim piece
- **STEP 3.** Remove the inner trim piece
- **STEP 4.** Remove the headlight bolts
- **STEP 5.** Unplug the headlights
- **STEP 6.** Transfer the light bulb sockets

PART II INSTALL HEADLIGHTS

- **STEP 1.** Install ALPHAREX headlights
- **STEP 2.** Install the optional DRL harness
- **STEP 3.** Test the headlight functions
- **STEP 4.** Adjust headlight level
- **STEP 5.** Complete installation

Disclaimer: This installation article is a tutorial guide. By reading this article, you agree it is for reference only and AlphaRex USA and its distributors make no guarantee on the finished results. Under no circumstances whatsoever shall AlphaRex USA nor its distributors be liable for any damage, misuse or personal injuries. If you do not fully understand the installation procedure, it is highly recommended that you seek help from professional mechanics to do the installation.

PART I REMOVE HEADLIGHTS

INSTALLATION TOOLS

PREPARE THESE TOOLS FOR INSTALLATION

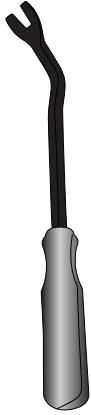

Metal
Panel
Popper



Phillips
Screwdriver

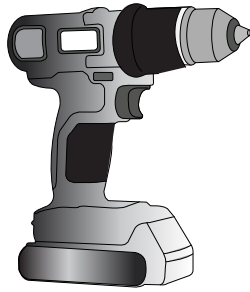

Power Tool
1/4 drill bit



1/4 Ratchet



1/4 Extension

10mm
8mm
7mm



Socket

NOTE: Whenever using a power tool, please make sure do not overtighten the screws.

STEP 1. DISCONNECTING THE NEGATIVE BATTERY TERMINAL

Whenever working on your vehicle, always start by disconnecting the negative battery terminal.



STEP 2. REMOVE THE OUTER TRIM PIECE

Start by extracting two push pins.



Take out the 2 X 7mm bolts from each side of the wheel well.



Gently pull outward to remove the outer trim piece and set it aside for later reinstallation.



STEP 3. REMOVE THE INNER TRIM PIECE

Unscrew the 6 X 10mm bolts, 1 X 8mm bolt, and remove 1 plastic clip from each side of the headlight.



STEP 4. REMOVE THE HEADLIGHT BOLTS

To remove the headlight, you need to take out 3 X 10mm bolts. Use an extension to remove the center bolt. Repeat the same step for the other side.



STEP 5. UNPLUG THE HEADLIGHTS

Disconnect the headlight connections to complete the removal process.



STEP 6. TRANSFER THE LIGHT BULB SOCKETS

After removing the headlights from the vehicle, take off the turn signal and side marker sockets as they will be transferred to the new ALPHAREX headlights.



Take out the existing side marker bulb from the socket. Connect the socket to the side marker connection and lock it in place.



Connect the turn signal socket to the female connector and securely lock the socket in place.



PART II INSTALL HEADLIGHTS

STEP 1. INSTALL ALPHAREX HEADLIGHTS



Before installing the new ALPHAREX headlights, ensure that all connections are properly reconnected. Be sure to connect the white wire to the optional DRL harness.

DO NOT USE DIELECTRIC GREASE!

We highly recommend that you test all functions with the engine on before you put everything back together.

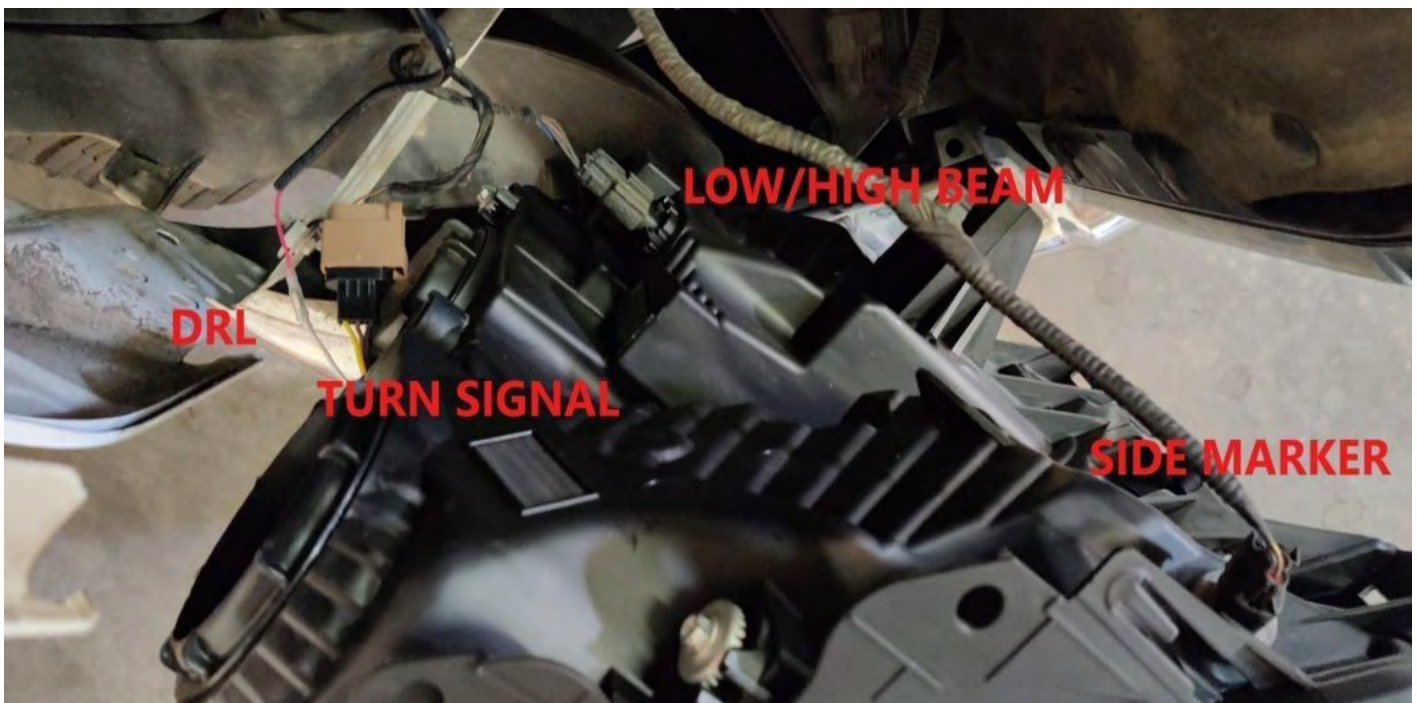

Once you have everything reassembled, you will need to drill a 1/4" hole to reuse the push pin for the outer trim piece.



STEP 2. INSTALL THE OPTIONAL DRL HARNESS

If you plan to install the optional DRL harness, connect the red wire from the DRL harness, with the short end going to the driver side and the long end to the passenger side. For more information about wiring the DRL harness:

[Read our article about How to wire the DRL harness?](#)



To enable the Daytime Running Lights (DRL) functionality during the day, you'll need to tap the grey wire into fuse #97.

STEP 3. TEST THE HEADLIGHT FUNCTIONS

Test the functions of your ALPHAREX headlights to ensure everything works properly.



STEP 4. ADJUST HEADLIGHT LEVEL

Once everything has been tested, aim your ALPHAREX headlights by parking 25ft from a wall and level the headlight evenly.

Turn clockwise: to lower the light

Turn counterclockwise: to raise the light

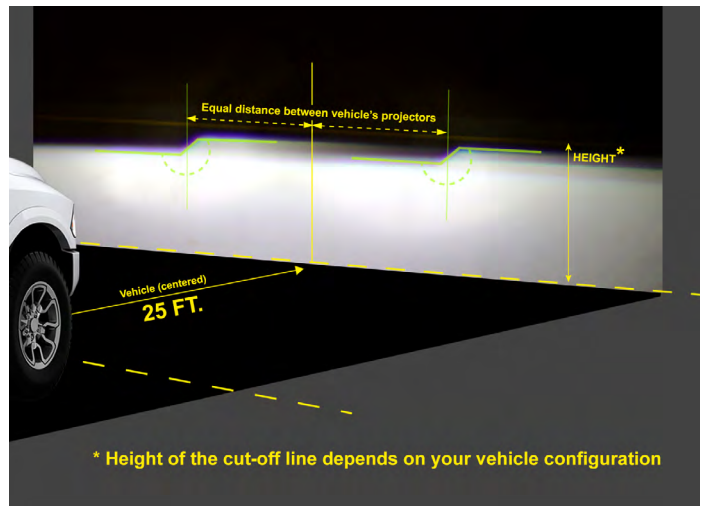

STEP 4. COMPLETE INSTALLATION

Congratulations! You have completed the installation for ALPHAREX **15-17 Ford F150 | 17-20 F150 Raptor HEADLIGHTS**.

