



Kawasaki Turn Signal System

Thank you for purchasing XTC Power Products Automatic Self-Canceling Turn Signal System. Our Easy Install Turn Signal System is unique from the other kits on the market. This kit is from our Plug & Play™ product line, with only connecting power, ground and plugs into the OEM Taillight Harness, utilizing the brake lights as Brake and Turn Signals.

Please read the instructions fully and familiarize yourself with the components before starting the install. Remember that these are basic instruction and you can install in other locations if desired, so feel free to be creative. The only places that have to interface is at the Rear Wire Harness and Busbar for Power and Ground. **NOTE:** When installing make sure that wires are run away from any hot or moving parts and properly secured.

ATS-KAW-SV3 Automatic Self-Canceling Turn Signal System

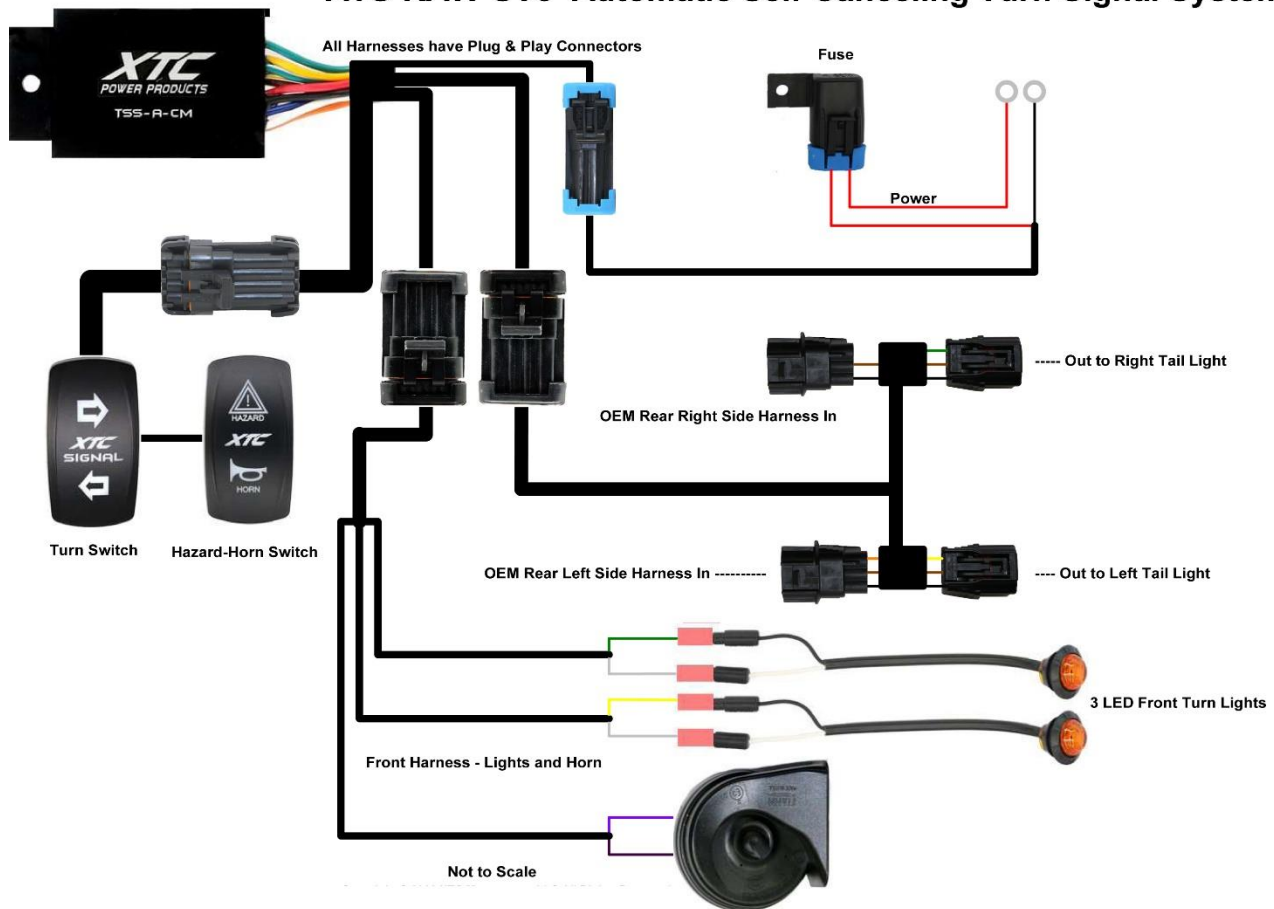

1. Remove the Center Dash and the center Cup holder console. To remove the Cup Holder lift up on the part behind the shifter while pushing the cup holder down to get the mounts past the dash- See our Video on-Line



- Using the provided Self Tapping Screw mount the Control Module on the frame in the dash.



- Take the short Harness KAV-SV3, starting at the driver side, un-plug the taillight and plug the harness with the yellow wire inline, run the other connector to the other side and plug it inline with the right taillight.



- Unroll the long extension cable and plug it into the 4-way connector that was just installed from the 4-pin connector down to the rear fire wall through the rubber grommet with the other cables behind the driver's seat, go across to the center console and run alongside the shifter up to the control module that was installed in step 2 and plug in. Keep it away from any **HOT or MOVING** parts. Using the provided Cable Ties secure it to the main OEM wire harness



- Install Front LED Turn Lights, the front LED Turn Indicators can be mounted with the rubber grommet or without. If the grommet is **not** being used drill 5/8" holes. If the grommet is being used drill 3/4" holes. Remove and install the rubber grommet from the LED into the hole if being used. Insert LED into the hole with the Top marking up. NOTE: the TOP marking is on the front of the LED lens.



6. Plug the Front Harness into the Control Module, run the wires through the fire wall to under the hood. Attach the Front Harness to the lights. The Green and White wire go to the right/passenger side LED, attach the Green to the Black and the White to the White, the Yellow and White wire go to the Left/Driver side LED, attach the Yellow to the Black and the White to the White. NOTE: Black wire is positive and go to the Green and Yellow, they will not work if reversed. White is ground. Secure the Harness using the provided cable ties.
7. Install Turn Switch – There are several places the Turn Switch can be mounted, so user preference may dictate where they are mounted. They can be mounted in the center of the dash or mount the turn switch on the left-hand side of the steering wheel as shown. Using a sharp box knife cut out the rectangle, do not over cut, trim as necessary. Push the switch Connector and wires through and apply grease (see Below) attach to switch and install in dash.



Dielectric Grease - Just like the OEM uses on their switches, we recommend using Dielectric Grease on all switch terminals, this keeps the water out, thereby reducing corrosion and helps increase reliability! Open the grease and put on the switch terminals and the connector terminals on both the Turn and Horn switches, the more the better.

8. Install Hazard Horn Switch, using a sharp box knife cut out the rectangle. Push the switch Connector and wires through and apply grease and attach to switch and install in dash.
9. Run the large connector from the switches over to the Control Module and plugin.
10. Install the Power Harness. Plug the harness into the Control Module and run to the factory Busbar. Attach the red wire to the left Positive terminal and the black ground wire to the right most ground terminal.

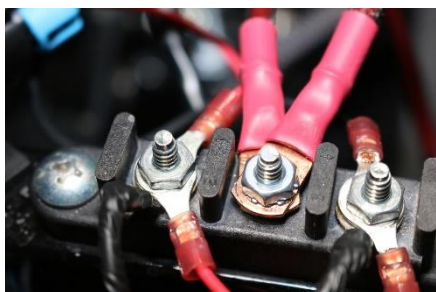

11. Mount the Horn, there is not much room under the hood so we have provided a screw, 2 fender washers and a KEPS nut, under the right or left fender there is a ½” hole on the fender support, using the fender washers, attach the horn to the support frame. Attach Violet and Black wire from front harness to the horn terminals. Secure the Harness using the provided cable ties.

12. Verify operation of all lights and secure all installed cables with supplied cable ties and re-install vehicle parts

Operation: The System uses momentary switches to activate. Press Right or Left Actuator accordingly. Will cancel as follows.

Press 1 Second for Lane Change, will stay on approx. 8 Seconds / 10 Flashes

Press 2 Seconds for Slowing to Turn Corners, will stay on approx. 20 Seconds / 30 Flashes

Press 5 Seconds for Traffic Lights when stopping and waiting, will stay on approx. 75 Seconds / 110 Fl.

The Systems Automatic Self-Cancelling may be overridden/Shut Off at any time by pushing the activated switch. Hazard Lights - press to activate and press again to deactivate, they do not self-cancel.

We can be reached by email at support@xtcpowerproducts.com

XTC Power Products
A Division of XTC Motorsports LLC
380 E Comstock Dr.
Chandler AZ 85225
480-558-8588
www.xtcpowerproducts.com

*Disclaimer: This kit is intended for off road use only and XTC Motorsports claims no responsibility for its use. It is up to the purchaser to make sure it complies with all Federal, State and Local laws. R2

Copyright © 2023 XTC MOTORSPORTS LLC, all rights reserved.