

Thank you for purchasing this Dynojet kit. This kit has been developed for a motorcycle which is set to the parameters listed at the right in the "Stage" description. If your motorcycle does not meet any of these parameters please check with Dynojet before installation. For technical assistance contact your Dynojet distributor or call Dynojet U.S.A. (800)-992-4993

2191 Mendenhall Dr. Suite 105
 North Las Vegas, NV 89081
 TEL: 702-399-1423
 FAX: 702-399-1431
 8am-5pm Pacific Time
 Monday through Friday

Website Address
<http://www.dynojet.com>

The manufacturer and seller make no warranties express or implied which extend beyond the description of the goods contained herein. Any description of this product is for the purpose of identifying it and shall not be deemed to create an express warranty.



2147.001
 U.S. Models Only

1995-2005 Kawasaki VN800 Vulcan
Stage 1

For mildly tuned machines using the stock air-box, with stock or K&N filter. May also be used with a good aftermarket exhaust system
 K&N filter #KA-8095

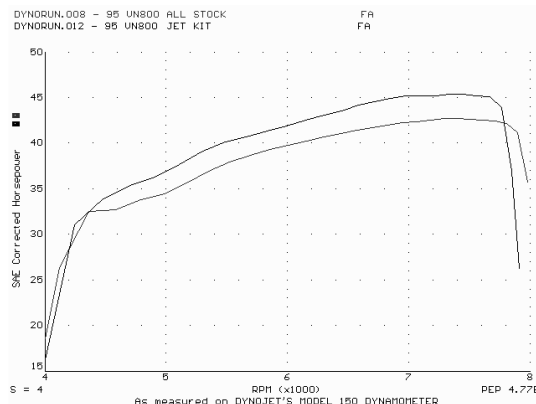

This graph shows a typical gain with a Dynojet jet kit.

WARNING

**NO SMOKING!
 NO OPEN FLAME!
 WHILE INSTALLING
 YOUR DYNOJET KIT**

Parts List

1	Main Jet	DJ130
1	Main Jet	DJ134
1	Fuel Needle	DNO106
1	E-clip	DE0001
2	Adjusting Washers	DW0001
1	Plug Drill	DD 5/32
1	Screw	DS0001

STAGE ONE INSTRUCTIONS

1. Remove the vacuum slide from the carb. Remove the stock needles and spacers, noting order of assembly (Fig.A).
2. Install the Dynojet needles on groove #2 from the top. Use all stock spacers (Fig. A). Install the small Dynojet washer above the E-clip. After installing the slide in the carb be sure to check slide movement manually before air box installation.
3. Remove the stock main jet and replace with the Dynojet main jet provided. If you are running the stock exhaust install the DJ130 main jet. If you are running an aftermarket exhaust with wide open baffles use the DJ134 main jet. Be sure that the jet you are changing is the main jet.
4. Locate the fuel mixture plug (Fig. B). If you see a screw head at Fig. B then proceed to the adjusting procedure. With the 5/32 drill bit provided carefully drill through the plug. **NOTE:** The mixture screw is directly underneath this plug, be ready to pull back on the drill the instant you break through. Use screw provided to secure and remove this plug. Carefully turn the mixture screw clockwise until lightly seated, then back out 3.5 turns.

Dynojet

2147.001

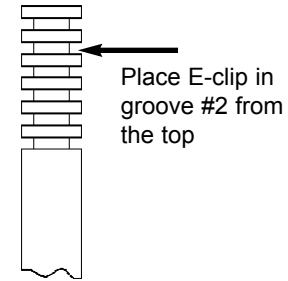

Fig. A

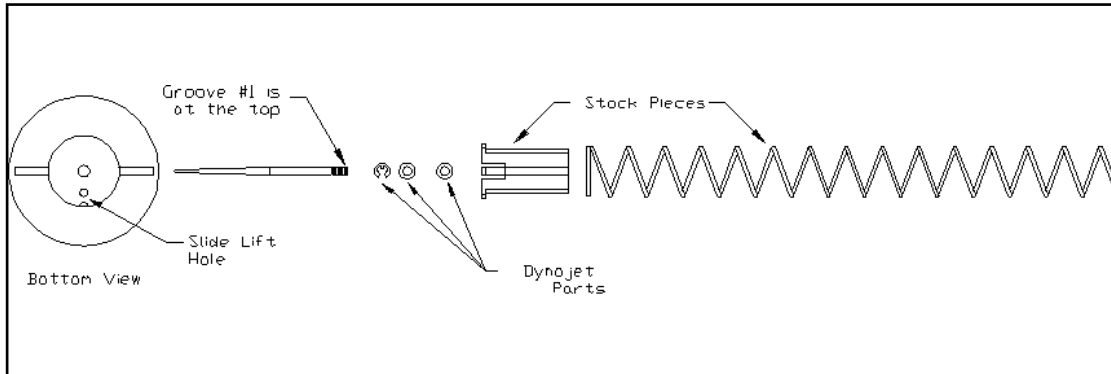

Fig. B

