

advanced FLOW engineering

Instruction Manual P/N: TM-2013B-D & TM-2013B-R



Make: **Scion/Subaru/Toyota** Model: **FR-S/BRZ/86** Year: **2013** Engine: **H4-2.0L**



- Please read the entire instruction manual before proceeding.
- Ensure all components listed are present.
- If you are missing any of the components, call customer support at 951-493-7100.
- Ensure you have all necessary tools before proceeding.
- Do not attempt to work on your vehicle when the engine is hot.
- Disconnect the negative battery terminal before proceeding.
- Retain factory parts for future use.

| Label | Qty. | Description | Part Number |
|-------|------|-------------------------|----------------------------------|
| A1 | 1 | Air Filter (Pro DRY S) | TF-9019D (Grey Media) TM-2013B-D |
| A2 | 1 | Air Filter (Pro 5R) | TF-9019R (Blue Media) TM-2013B-R |
| B | 1 | Tube | 05-T2013B1 |
| C | 1 | Housing | 05-T2013B2 |
| D | 1 | Coupling 3"ID x 2"L | 05-01106 |
| E | 2 | Clamp, 048 | 03-50007 |
| F | 1 | Grommet | 03-50033 |
| G | 1 | Coupling 1-1/2"ID x 2"L | 05-01198 |
| H | 1 | Clamp, 096 | 03-50003 |
| I | 2 | Screw, M4 x .7 x 8 | 03-50034 |
| J | 2 | Mini Clamp, 024 | 03-50093 |

Installation will require the following tools:

Phillips screw driver, 8mm nut driver, ratchet, extension, 10mm socket & pliers

Note: Legal in California for use on race vehicles only. The use of this device on vehicles used on public streets or highways is strictly prohibited in California and others states that have adopted California emission regulations.

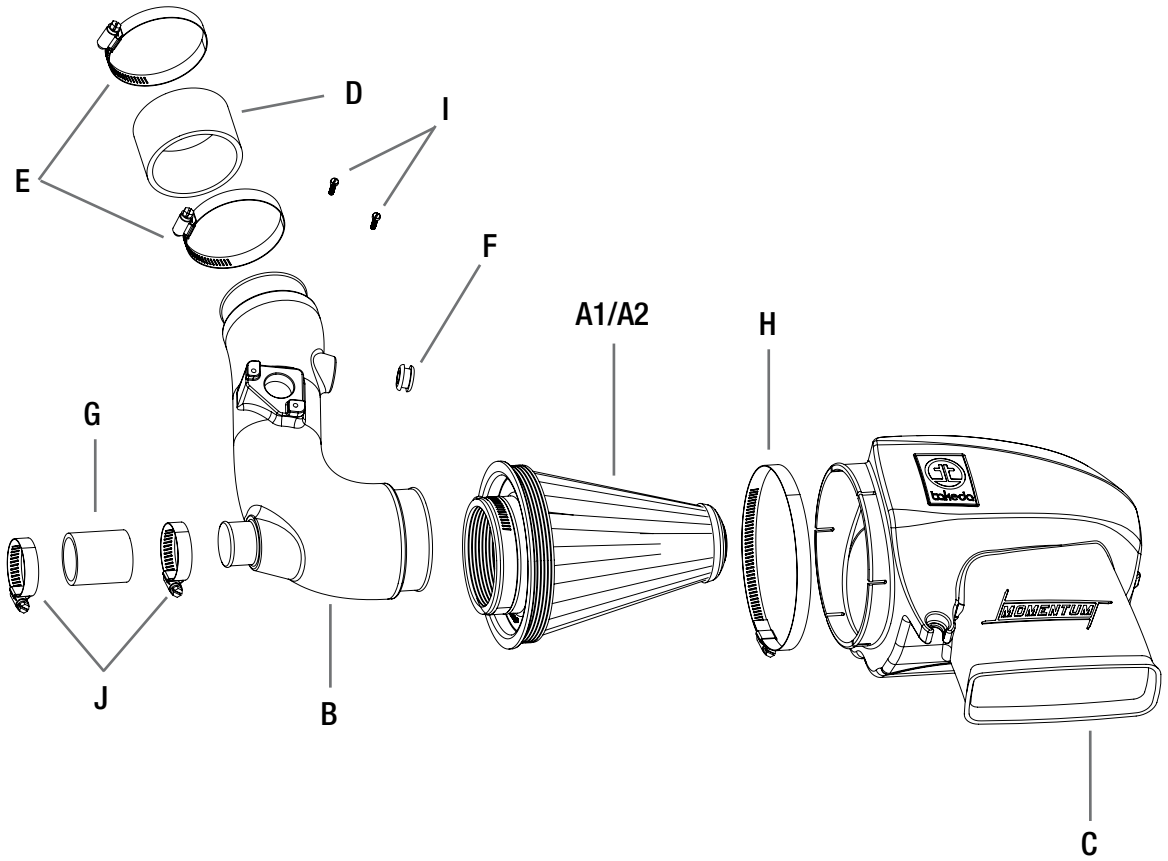

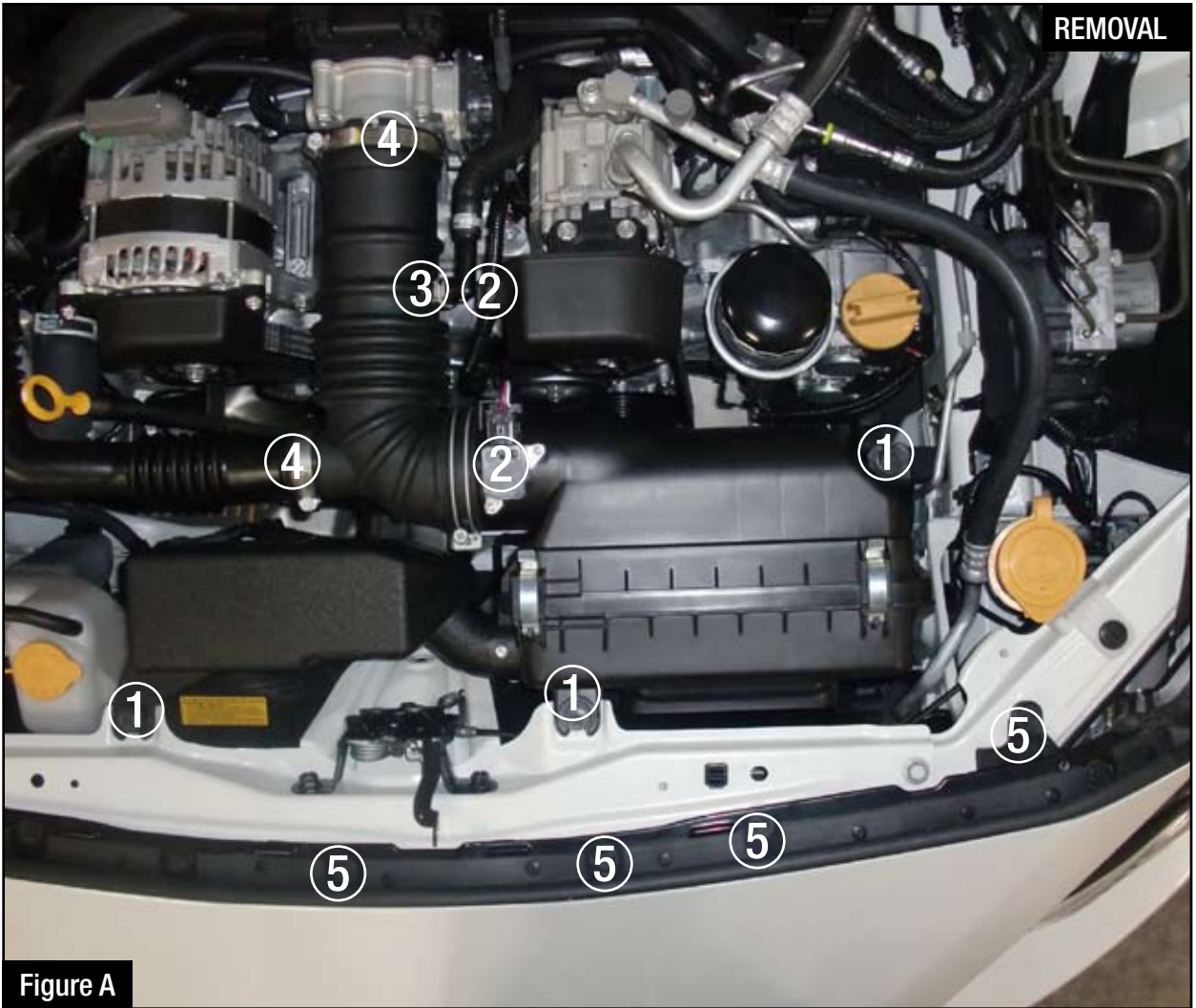

Refer to Figure A for step 1-5

Step 1: Remove the three 10mm bolts on the OE housing (1).

Step 2: Unplug the MAF sensor and unclip the wire harness from the OE intake tube (2).

Step 3: Remove the crank case hose from the OE tube (3).

Step 4: Loosen the clamp off the throttle body and cabin sound chamber tube, then remove the OE intake system out of the vehicle (4).

Step 5: Remove the five 10mm bolts and two push clips on the front bumper rail (5).



Figure B

Refer to Figure B for step 6

Step 6: Remove the three push clips on the driver side inside fender well (6) connecting to the bumper, and also the one by the amber light (7).



Figure C

Refer to Figure C for steps 7

Step 7: With a flat head screwdriver push on the bottom side of the amber and pry out. Pop out the bottom side, then remove the rest of the amber light.



Figure D

Refer to Figure D for steps 8-9

Step 8: Gently pull the right side of the bumper to gain access to the OE scoop.

Step 9: Remove the OE scoop off the vehicle by removing the two 10mm bolts (8) and install bumper back on.



Figure E

Refer to Figure E for steps 10-13

Step 10: Remove two of the OE grommets off the OE housing that you removed in step one and install them on the Takeda housing (Refer to top right photo).

Step 11: Install the large hose clamp onto the housing and air filter as shown (Refer to top right photo).

Step 12: Install the Takeda Housing into the vehicle using the OE hardware (9) .

Step 13: Place the silicone coupling onto the throttle body with the supplied clamps (10) .

INSTALL



Figure G

Figure F

Refer to Figure F for steps 14-18

(If you would like to use the sound chamber, Drill out the intake tube as shown in Figure G)

Step 14: Install your Takeda intake tube into the vehicle.

Step 15: Remove the MAF sensor off the OE air box and install onto the Takeda tube with the supplied hardware (11).

Step 16: Install the supplied rubber grommet onto the intake tube (12) and reinstall your factory crank case vent line.

Step 17: Attach the sound chamber to the intake tube using the supplied coupling and clamps (13).

Step 18: Reconnect battery, your installation is now complete!

Pro DRY S Air Filter



P/N: TF-9019D

Pro 5R Air Filter



P/N: TF-9019R

Pro DRY S Restore Kit



P/N: TP-7015C

Takeda Tee



P/N: TP-7004T M
P/N: TP-7005T L
P/N: TP-7006T XL
P/N: TP-7007T 2XL

Key Chain

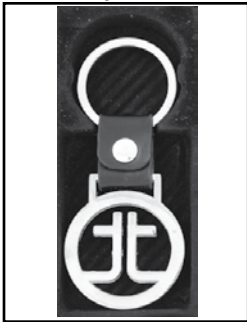

P/N: TP-7018K

Key Chain



P/N: TP-7024K

Mascot Decal

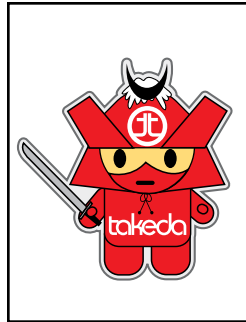

P/N: TP-7003D

Lic. Plate Frame



P/N: TP-7014F

To purchase any of the items above, view airflow charts, dyno graphs, photos, and video; please go to aFepower.com.

Warranty

General Terms:

- aFe warrants their products to be free from manufacturer's defects due to workmanship and material.
- This warranty applies only to the original purchaser of the product and is non-transferrable.
- Proof of purchase of the aFe product is required for all warranty claims.
- Warranty is valid provided aFe instructions for installation and/or cleaning were properly followed.
- Proper maintenance with regular inspections of product is required to insure warranty coverage.
- Damage due to improper installation, abuse, unauthorized repair or alteration is not warranted.
- Incidental or consequential damages or cost, including installation and removal of part, incurred due to failure of aFe product is not covered under this warranty.
- All warranty is limited to the repair and/or replacement of the aFe part. To request Return Goods Authorization ("RGA"), email RGA@afepower.com or call (951)493-7100. Upon receipt of the RGA, you must return the product to the address provided in the RGA, freight prepaid and accompanied with a dated proof of purchase and the RGA. Upon receipt of the defective product and upon verification of proof of purchase, aFe will either repair or replace the defective product within a reasonable time, not to exceed thirty days.

| Product Category | P/N Prefix | Warranty duration |
|----------------------------------|--------------------------------|--------------------------|
| Direct OE Replacement Filters | 10, 11, 30, 31, 71, 73 | Life of the vehicle |
| Racing Filters | 18 | 1 year |
| Universal | 21, 24, 72, TF | 2 years |
| Air Intake Systems | 50, 51, 54, 55, 75, TR, TA, TL | 2 years |
| Exhaust Systems | 49 | 2 years |
| Intercoolers & Intercooler Tubes | 46-2 | 2 years |
| Intake Manifolds | 46-1 | 2 years |
| Differential Cover | 46-7 | Life of the vehicle |
| Exhaust Manifolds | 46 | 2 years |
| Throttle Body Spacers | 46-3 | 2 years |
| Turbochargers | 46-6 | 2 years* |
| Fluid Filters | 44 | 90 days |
| Pre-Filters | 28 | 2 years |
| Heavy Duty OE Replacement | 70 | 2 years |
| PowerSports OE Replacement | 81, 87 | 2 years |
| PowerSports Intake Systems | 85 | 2 years |

No other warranty expressed or implied applies nor is any person or advanced FLOW engineering authorized to assume any other warranty. Some States do not allow the exclusion or limitation of incidental or consequential damages or do not allow limitations on how long an implied warranty lasts, so the above limitations or exclusions may not apply to you. This warranty gives you specific legal rights, and you may also have other rights which vary from State to State.

*See turbocharger warranty for more info

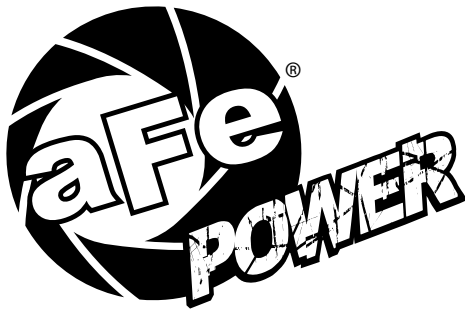

advanced FLOW engineering, inc.

252 Granite Street Corona, CA 92879

TEL: 951.493.7100 • TECH: 951.493.7100 x23

E-Mail: Tech@aFepower.com