



INSTALLATION INSTRUCTIONS

MAKE: VOLKSWAGEN
MODEL: PASSAT TDI
YEAR: 2012
ENGINE: L4-2.0L

**Cat Back
Stainless Steel
49-46404**

aFe recommends professional installation on our products.

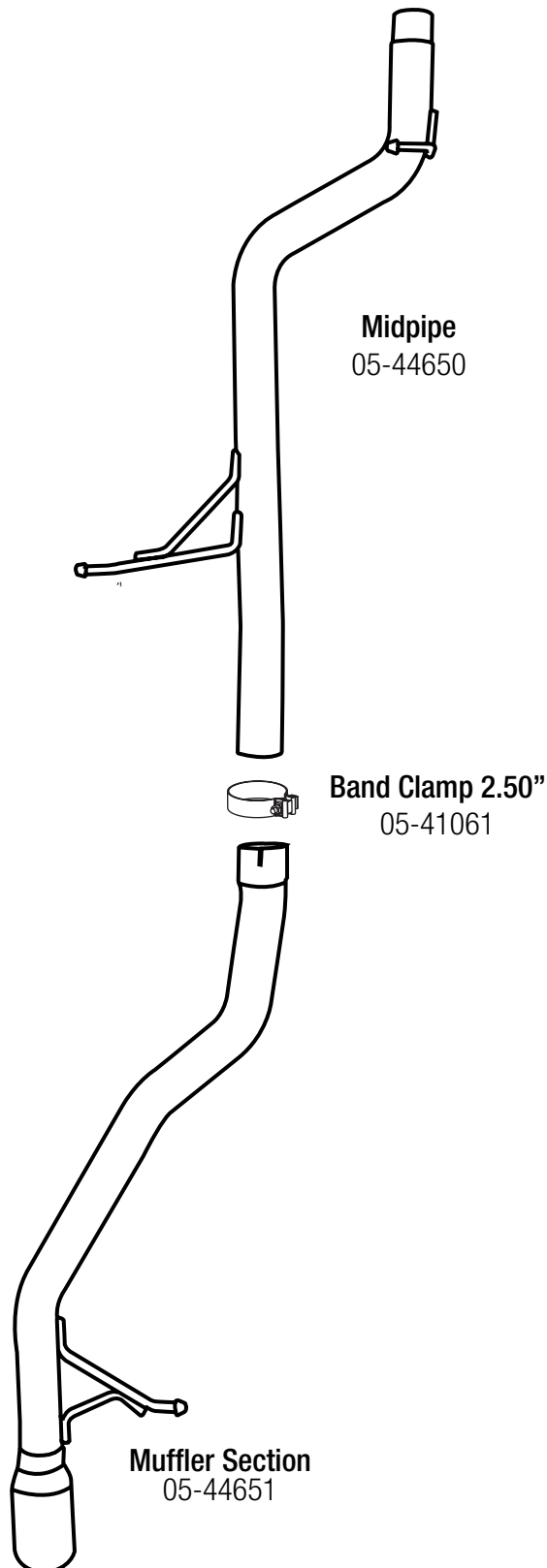

Caution: Allow time for your vehicle to cool down prior to installation. When working on or under your vehicle proceed with caution. Exhaust systems reach high temperatures and may cause serious burns. Wear protective safety equipment; eye goggles and gloves to ensure a safe installation.

Step 1: (Read Instructions prior to installation) Secure vehicle on jack stands (Refer to your manual for specified jack stand positions).

Step 2: Remove brace under the center of the OE exhaust system going across the chassis.

Step 3: Loosen the exhaust clamp of the OE exhaust mid pipe.

Step 4: Cut off the rear section of the OE mid pipe after the suspension. (This is necessary to remove the OE exhaust system)

Step 5: Remove muffler section by sliding off the rubber hanger mount.

Step 6: Remove the mid pipe section by sliding off the two rubber hanger mounts.

Step 7: Install the aFe front mid pipe section but do not tighten, secure mid pipe on the two rubber hanger mounts.

Step 8: Using (x1) supplied 2.5" band clamp, install the aFe muffler section onto the mid pipe and hanger mount. Do not tighten band clamp.

Step 9: Align the exhaust system and then tighten the OE exhaust clamp, then the 2.5" band clamp from step 8.

Step 10: Re-install the exhaust brace removed in step 2.

Step 11: Re-check all your work.

Note: It is normal for your exhaust system to emit smoke for the first few minutes upon initial start-up.